

SPEED QUEEN MULTI-HOUSING

MANUAL HOMESTYLE COMMERCIAL TOP LOAD WASHER

Built for Reliable Performance

Speed Queen® top load washers are durably constructed using premium materials for long-lasting, reliable performance and superior wash results. If you want your laundry done right, you want a Speed Queen. Our machines are manufactured using metal instead of plastic. They're built with rugged, commercial-grade construction. Our world-class test lab rigorously pushes our products far beyond the conditions they're likely to ever face. We work hard at every point of our manufacturing process to ensure that our machines reflect that belief.

- Durable stainless steel wash tub
- Extract speed of 710 RPMs spins clothes out drier
- Automatic Balancing Suspension provides the industry's best out-of-balance handling, completing wash cycles without interruption
- Curved four-vane polypropylene agitator provides 210° agitation stroke which delivers superior washability
- Low water consumption

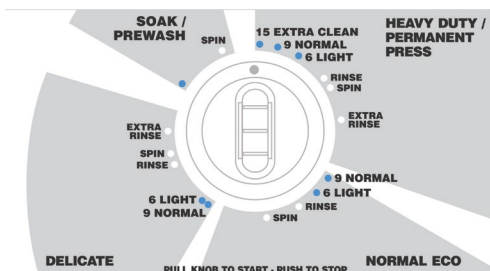
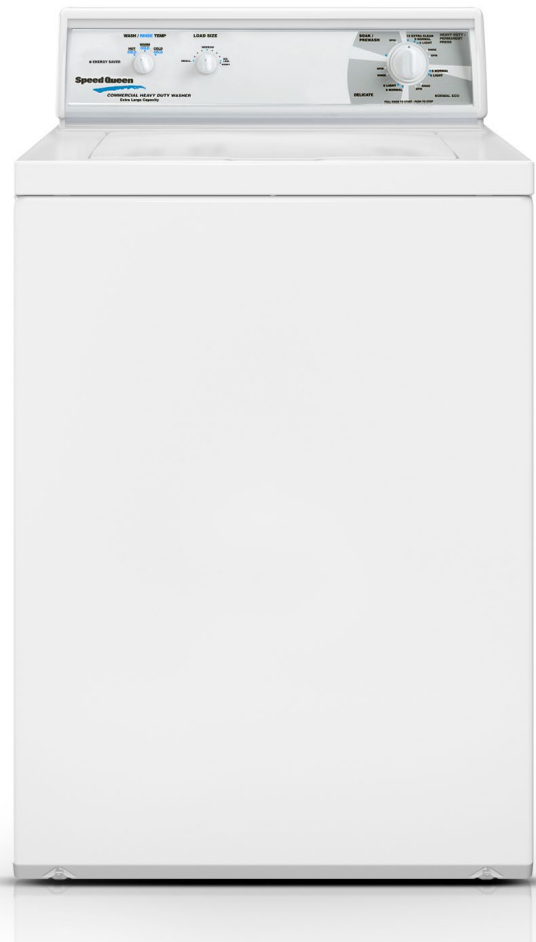

Manual homestyle control provides easy to start activation indicated by "In Use" light.

SPECIFICATIONS

COMMERCIAL TOP LOAD WASHER

MODEL - see below for all models and activation available	
CONTROL OPTION	Manual Homestyle
COLOR	White
CAPACITY - lb (kg)	16 (7.3)
OVERALL WIDTH - in (mm)	25.625 (651)
OVERALL DEPTH - in (mm)	28 (711)
OVERALL HEIGHT - in (mm)	43 (1092)
CYLINDER VOLUME - cu. ft. (liters)	3.22 (91.2)
SPIN SPEED G-FORCE (RPM)	150 (710)
MOTOR SIZE - HP (kw)	0.5 (0.37)
WATER CONSUMPTION PER CYCLE - g (liter)	21.6 (81.8)
WF (WATER FACTOR) - liters/liter/cycle (gal/ft ³)	0.9 (6.8)
MEF (Modified Energy Factor) ft ³ /kWh/cycle (Liters/kWh/cycle)	1.29 (36.5)
AVAILABLE WATER TEMPERATURES	Hot, Warm, Cold
AVAILABLE CYCLES	Soak/Prewash, Heavy Duty/Permanent Press, Normal Eco, Delicate
ELECTRICAL REQUIREMENTS (v/Hz/Ph-Amp)	120/60/1 - 15 Amp
WATER PRESSURE - p.s.i. (bar)	20-120 (1.4/8.3)
DRAIN	Pump
CYLINDER FINISH	Stainless Steel
NET WEIGHT - lb (kg)	186 (84.4)
SHIPPING WEIGHT - lb (kg)	196 (88.9)
SHIPPING DIMENSIONS APPROX. - in (mm)	Width 28 (711)
	Depth 30 (762)
	Height 45 (1143)
AGENCY APPROVALS	cULus

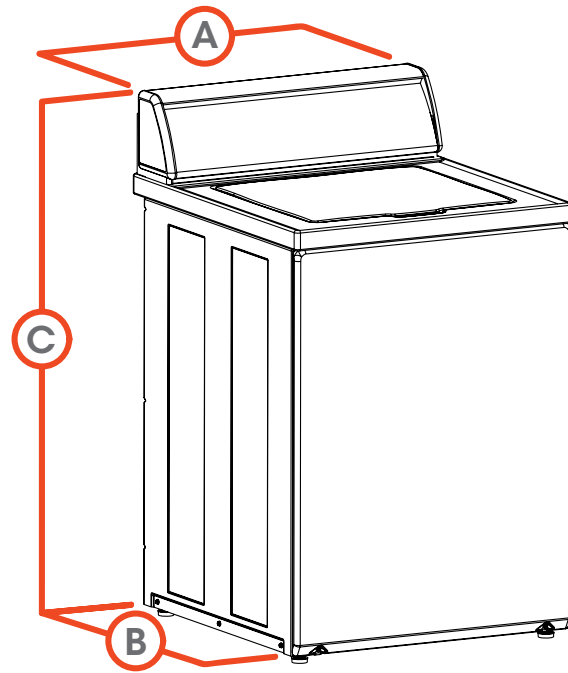

A. OVERALL WIDTH - in (mm)	25.625 (651)
B. OVERALL DEPTH - in (mm)	28 (711)
C. OVERALL HEIGHT - in (mm)	43 (1092)

MODELS	ACTIVATION
LWN432SP113TW04	

For the most accurate information, the installation guide should be used for all design and construction purposes. Due to continuous product improvements, design and specifications subject to change without notice. The quality management system of Alliance Laundry Systems' Ripon facility has been registered to ISO 9001:2000.